

When Ordering,
Please Specify
Type of Material:

- Carbon
- Stainless
- Aluminum
- Galvanized Steel

Standard Long Radius Bends

• EXPANDED ENDS AVAILABLE UPON REQUEST, EXCEPT ON 8" AND 10" BENDS & ALL 11 GAUGE BENDS

A (OD)	B (CLR)	GAUGE	C	90° PART NO.	C	45° PART NO.
2-1/8"	24"	16	30"	16-212242	15-15/16"	16-212241
2-1/8"	24"	11	30"	11-212242	15-15/16"	11-212241
2-1/8"	36"	16	42"	16-212362	20-15/16"	16-212361
2-1/8"	36"	11	42"	11-212362	20-15/16"	11-212361
2-1/2"	24"	16	30"	16-250242	15-15/16"	16-250241
2-1/2"	24"	11	30"	11-250242	15-15/16"	11-250241
2-1/2"	36"	16	42"	16-250362	20-15/16"	16-250361
2-1/2"	36"	11	42"	11-250362	20-15/16"	11-250361
3"	24"	16	30"	16-300242	15-15/16"	16-300241
3"	24"	11	30"	11-300242	15-15/16"	11-300241
3"	30"	16	36"	16-300302	18-7/16"	16-300301
3"	30"	11	36"	11-300302	18-7/16"	11-300301
3"	36"	16	42"	16-300362	20-15/16"	16-300361
3"	36"	11	42"	11-300362	20-15/16"	11-300361
3"	38"	16	44"	16-300382	21-3/4"	16-300381
3"	38"	11	44"	11-300382	21-3/4"	11-300381
3"	48"	16	54"	16-300482	25-7/8"	16-300481
3"	48"	11	54"	11-300482	25-7/8"	11-300481
3-1/2"	30"	16	37"	16-350302	19-7/16"	16-350301
3-1/2"	30"	11	37"	11-350302	19-7/16"	11-350301
3-1/2"	36"	16	43"	16-350362	21-15/16"	16-350361
3-1/2"	36"	11	43"	11-350362	21-15/16"	11-350361
3-1/2"	48"	16	55"	16-350482	26-7/8"	16-350481
3-1/2"	48"	11	55"	11-350482	26-7/8"	11-350481
4"	24"	16	32"	16-400242	17-15/16"	16-400241
4"	24"	11	32"	11-400242	17-15/16"	11-400241
4"	30"	16	38"	16-400302	20-7/16"	16-400301
4"	30"	11	38"	11-400302	20-7/16"	11-400301
4"	36"	16	44"	16-400362	22-15/16"	16-400361
4"	36"	11	44"	11-400362	22-15/16"	11-400361
4"	48"	16	56"	16-400482	27-7/8"	16-400481
4"	48"	11	56"	11-400482	27-7/8"	11-400481
4"	60"	16	68"	16-400602	32-7/8"	16-400601
4"	60"	11	68"	11-400602	32-7/8"	11-400601
5"	30"	14	40"	14-500302	22-7/16"	14-500301
5"	30"	11	40"	11-500302	22-7/16"	11-500301
5"	48"	14	58"	14-500482	29-7/8"	14-500481
5"	48"	11	58"	11-500482	29-7/8"	11-500481
6"	30"	14	42"	14-600302	24-7/16"	14-600301
6"	30"	11	42"	11-600302	24-7/16"	11-600301
6"	48"	14	60"	14-600482	31-7/8"	14-600481
6"	48"	11	60"	11-600482	31-7/8"	11-600481
6"	60"	14	72"	14-600602	36-7/8"	14-600601
6"	60"	11	72"	11-600602	36-7/8"	11-600601
8"	32"	14	48"	14-800322	25-1/4"	14-800321
8"	32"	11	48"	11-800322	25-1/4"	11-800321
8"	48"	14	64"	14-800482	31-7/8"	14-800481
8"	48"	11	64"	11-800482	31-7/8"	11-800481
10"	48"	12	70"	12-1000482*	41-7/8"	12-1000481*

- NOMINAL STANDARD TANGENT IS TWO TIMES TUBE OD, 6" MINIMUM
- ALL STANDARD BENDS HAVE STRAIGHT ENDS
- NOMINAL STANDARD TANGENT FOR 10" BEND IS 22"
- * STAINLESS PARTS ARE SEGMENTED

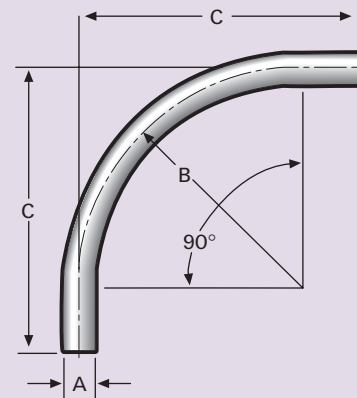

90° Long Radius Bend

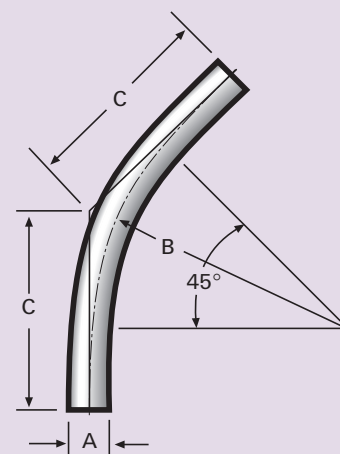

45° Long Radius Bend

KEY

- OD = Outside Diameter
- CLR = Center Line Radius
- C = Center to end
- All reference dimensions are nominal.

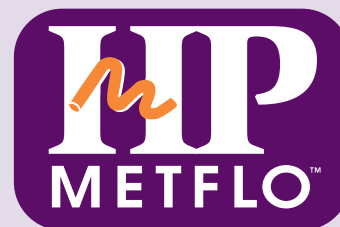

Fittings

When Ordering,
Please Specify
Type of Material:

- Carbon
- Stainless
- Aluminum
- Galvanized Steel

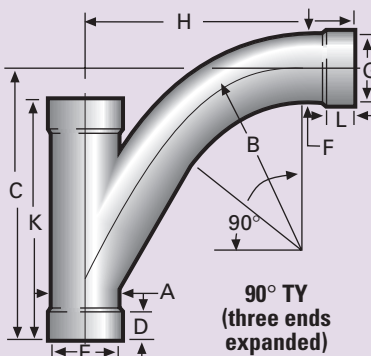
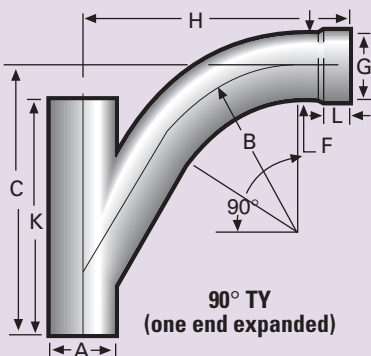

KEY

OD = Outside Diameter
 D = Expansion Depth 1-3/8" through 4" OD, 1-5/8" for 5" and 6" OD
 A = Outside Diameter (OD) = E Inside Diameter (ID)
 F = Outside Diameter (OD) = G Inside Diameter (ID)
 L = Expansion Depth 1-3/8" through 4" OD, 1-5/8" for 5" and 6" OD
 All reference dimensions are nominal.

Standard 90° TY's

- 2-1/8" through 14" OD
- Wall Thickness: 16, 14, 12, (11 Gauge Available in Straight Ends Only)
- (16 Gauge: 2-1/8" to 4" OD) (14 Gauge: 5" to 8" OD) (12 Gauge: 10" to 14" OD)
- Materials: Carbon, Stainless, Aluminum, Galvanized Steel

- 11 GAUGE TY'S AVAILABLE (STRAIGHT ENDS ONLY)
- STRAIGHT AND EXPANDED COMBINATIONS AVAILABLE
- STRAIGHT ENDS AVAILABLE ON ALL SIZES BY REQUEST

SIZE	GAUGE	A (OD)	B	C	F (OD)	H	K	PART NO.
2-1/8"	16	2-1/8"	5"	9-5/32"	2-1/8"	8-13/16"	9-1/2"	TY-215
2-1/2" x 2-1/8"	16	2-1/2"	5"	9-11/32"	2-1/8"	9"	10"	TY-255
2-1/2"	16	2-1/2"	6"	10-1/2"	2-1/2"	10-1/32"	10"	TY-256
3" x 2-1/8"	16	3"	5"	9-19/32"	2-1/8"	9-1/4"	10-1/2"	TY-305
3" x 2-1/2"	16	3"	6"	10-3/4"	2-1/2"	10-9/32"	10-1/2"	TY-306
3"	16	3"	7-1/2"	12-3/8"	3"	11-25/32"	11-1/2"	TY-307
3-1/2" x 2-1/8"	16	3-1/2"	5"	9-27/32"	2-1/8"	9-1/2"	11"	TY-355
3-1/2" x 2-1/2"	16	3-1/2"	6"	11"	2-1/2"	10-17/32"	11"	TY-356
3-1/2" x 3"	16	3-1/2"	7-1/2"	12-5/8"	3"	12-1/32"	13"	TY-357
3-1/2"	16	3-1/2"	8-3/4"	14-1/8"	3-1/2"	13-11/32"	13"	TY-358
4" x 2-1/8"	16	4"	5"	10-3/32"	2-1/8"	9-3/4"	12"	TY-405
4" x 2-1/2"	16	4"	6"	11-1/4"	2-1/2"	10-25/32"	12"	TY-406
4" x 3"	16	4"	7-1/2"	12-7/8"	3"	12-9/32"	12"	TY-407
4" x 3-1/2"	16	4"	8-3/4"	14-3/8"	3-1/2"	13-19/32"	14"	TY-408
4"	16	4"	10"	15-7/8"	4"	14-29/32"	14"	TY-409
5" x 2-1/8"	14	5"	5"	10-19/32"	2-1/8"	10-1/4"	13"	TY-505
5" x 2-1/2"	14	5"	6"	11-3/4"	2-1/2"	11-9/32"	13"	TY-506
5" x 3"	14	5"	7-1/2"	13-3/8"	3"	12-25/32"	15-1/2"	TY-507
5" x 3-1/2"	14	5"	8-3/4"	14-7/8"	3-1/2"	14-3/32"	15-1/2"	TY-508
5" x 4"	14	5"	10"	16-3/8"	4"	15-13/32"	15-1/2"	TY-509
5"	14	5"	12-1/2"	19-3/8"	5"	18-5/8"	18-1/2"	TY-515
6" x 2-1/8"	14	6"	5"	11-3/32"	2-1/8"	10-3/4"	15"	TY-605
6" x 2-1/2"	14	6"	6"	12-1/4"	2-1/2"	11-25/32"	15"	TY-606
6" x 3"	14	6"	7-1/2"	13-7/8"	3"	13-9/32"	15"	TY-607
6" x 3-1/2"	14	6"	8-3/4"	15-3/8"	3-1/2"	14-19/32"	17"	TY-608
6" x 4"	14	6"	10"	16-7/8"	4"	15-29/32"	17"	TY-609
6" x 5"	14	6"	12-1/2"	19-7/8"	5"	19-1/8"	21"	TY-614
6"	14	6"	15"	22-7/8"	6"	22-11/32"	21"	TY-615
8" x 2-1/8"	14	8"	5"	12-3/32"	2-1/8"	11-3/4"	18"	TY-805
8" x 2-1/2"	14	8"	6"	13-1/4"	2-1/2"	12-25/32"	18"	TY-806
8" x 3"	14	8"	7-1/2"	14-7/8"	3"	14-9/32"	18"	TY-807
8" x 3-1/2"	14	8"	8-3/4"	16-3/8"	3-1/2"	15-19/32"	21"	TY-808
8" x 4"	14	8"	10"	17-7/8"	4"	16-29/32"	21"	TY-809
8" x 5"	14	8"	12-1/2"	20-7/8"	5"	20-1/8"	24"	TY-814
8" x 6"	14	8"	15"	23-7/8"	6"	23-11/32"	24"	TY-815
8"	14	8"	20"	29-7/8"	8"	29-17/32"	29"	TY-816
10" x 2-1/8"	12	10"	5"	13-3/32"	2-1/8"	12-3/4"	21"	TY-1005

- EXPANDED ENDS STANDARD THROUGH 6" SIZE
- * SEGMENTED



When Ordering,
Please Specify
Type of Material:

- Carbon
- Stainless
- Aluminum
- Galvanized Steel

Standard 90° TY's - cont.

- 11 GAUGE TY'S AVAILABLE (STRAIGHT ENDS ONLY)
- STRAIGHT AND EXPANDED COMBINATIONS AVAILABLE
- STRAIGHT ENDS AVAILABLE ON ALL SIZES BY REQUEST

SIZE	GAUGE	A (OD)	B	C	F (OD)	H	K	PART NO.
10" x 2-1/2"	12	10"	6"	14-1/4"	2-1/2"	13-25/32"	21"	TY-1006
10" x 3"	12	10"	7-1/2"	15-7/8"	3"	15-9/32"	21"	TY-1007
10" x 3-1/2"	12	10"	8-3/4"	17-3/8"	3-1/2"	16-17/32"	24"	TY-1008
10" x 4"	12	10"	10"	18-7/8"	4"	17-29/32"	24"	TY-1009
10" x 5"	12	10"	12-1/2"	21-7/8"	5"	21-1/8"	24"	TY-1014
10" x 6"	12	10"	15"	24-7/8"	6"	24-11/32"	28"	TY-1015
10" x 8"	12	10"	20"	30-7/8"	8"	30-17/32"	32"	TY-1016
10"	12	10"	32"	40-3/8"	10"	42-25/32"	36"	TY-1017
12" x 2-1/8"	12	12"	5"	14-3/32"	2-1/8"	13-3/4"	24"	TY-1205
12" x 2-1/2"	12	12"	6"	15-1/4"	2-1/2"	14-25/32"	24"	TY-1206
12" x 3"	12	12"	7-1/2"	16-7/8"	3"	16-9/32"	24"	TY-1207
12" x 3-1/2"	12	12"	8-3/4"	18-3/8"	3-1/2"	17-19/32"	27"	TY-1208
12" x 4"	12	12"	10"	19-7/8"	4"	18-29/32"	27"	TY-1209
12" x 5"	12	12"	12-1/2"	22-7/8"	5"	22-1/8"	27"	TY-1214
12" x 6"	12	12"	15"	25-7/8"	6"	25-11/32"	31"	TY-1215
12" x 8"	12	12"	20"	31-7/8"	8"	31-17/32"	35"	TY-1216
12" x 10"	12	12"	32"	41-3/8"	10"	43-25/32"	39"	TY-1217
12"	12	12"	36"*	46-7/8"	12"	49-1/8"	43"	TY-1218
14" x 8"	12	14"	20"	32-7/8"	8"	32-17/23"	38"	TY-1416
14" x 10"	12	14"	32"	42-3/8"	10"	44-25/32"	42"	TY-1417
14" x 12"	12	14"	36"*	47-7/8"	12"	50-1/8"	46"	TY-1418
14"	12	14"	36"*	51-3/8"	14"	50-3/4"	52"	TY-1419

- EXPANDED ENDS STANDARD THROUGH 6" SIZE
- * SEGMENTED

KEY

OD = Outside Diameter
 F = Outside Diameter (OD) = G = Inside Diameter (ID)
 L = Expansion Depth 1-3/8" through 4" OD, 1-5/8" for 5" and 6" OD
 All reference dimensions are nominal.

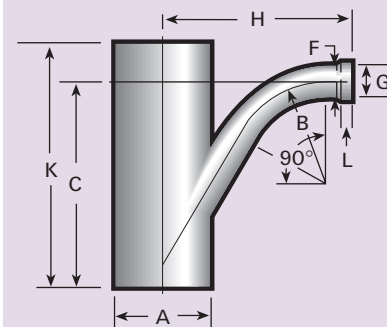

90° TY
(one end expanded)

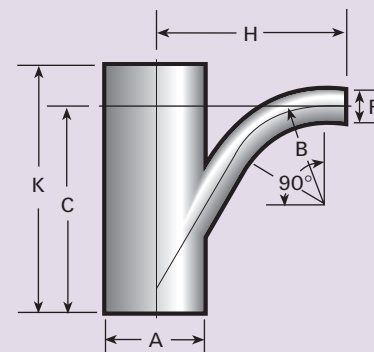

90° TY
(straight ends)

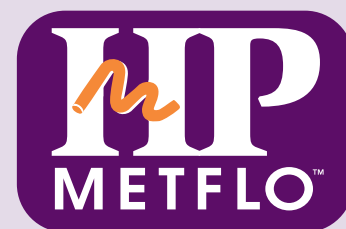

Fittings

When Ordering,
Please Specify
Type of Material:

- Carbon
- Stainless
- Aluminum
- Galvanized Steel

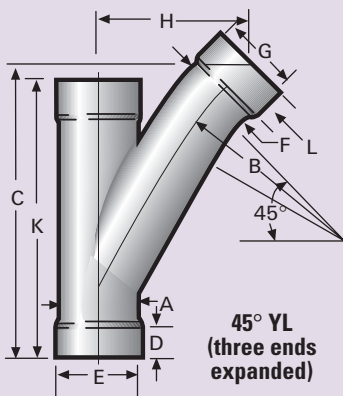
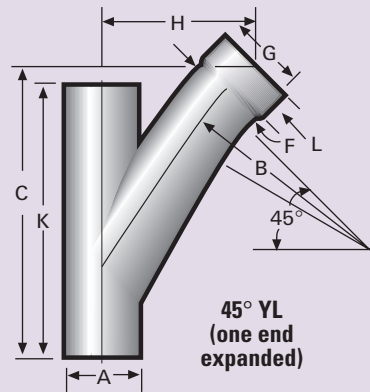

Standard 45° YL's

- 2-1/8" through 14" OD
- Wall Thickness: 16, 14, 12, (11 Gauge Available in Straight Ends Only)
- (16 Gauge: 2-1/8" to 4" OD) (14 Gauge: 5" to 8" OD) (12 Gauge: 10" to 14" OD)
- Materials: Carbon, Stainless, Aluminum, Galvanized Steel

- 11 GAUGE YL'S AVAILABLE (STRAIGHT ENDS ONLY)
- STRAIGHT AND EXPANDED COMBINATIONS AVAILABLE
- STRAIGHT ENDS AVAILABLE ON ALL SIZES BY REQUEST

SIZE	GAUGE	A (OD)	B	C	F (OD)	H	K	PART NO.
2-1/8"	16	2-1/8"	5"	9-3/32"	2-1/8"	4-11/16"	9-1/2"	YL-2151
2-1/2" X 2-1/8"	16	2-1/2"	5"	9-9/32"	2-1/8"	4-7/8"	10"	YL-2551
2-1/2"	16	2-1/2"	6"	10-5/32"	2-1/2"	5-3/16"	10"	YL-2561
3" X 2-1/8"	16	3"	5"	9-17/32"	2-1/8"	5-1/8"	10-1/2"	YL-3051
3" X 2-1/2"	16	3"	6"	10-13/32"	2-1/2"	5-7/16"	10-1/2"	YL-3061
3"	16	3"	7-1/2"	11-19/32"	3"	5-29/32"	11-1/2"	YL-3071
3-1/2" X 2-1/8"	16	3-1/2"	5"	9-25/32"	2-1/8"	5-3/8"	11"	YL-3551
3-1/2" X 2-1/2"	16	3-1/2"	6"	10-21/32"	2-1/2"	5-11/16"	11"	YL-3561
3-1/2" X 3"	16	3-1/2"	7-1/2"	11-27/32"	3"	6-5/32"	13"	YL-3571
3-1/2"	16	3-1/2"	8-3/4"	12-31/32"	3-1/2"	6-9/16"	13"	YL-3581
4" X 2-1/8"	16	4"	5"	10-1/32"	2-1/8"	5-5/8"	12"	YL-4051
4" X 2-1/2"	16	4"	6"	10-29/32"	2-1/2"	5-15/16"	12"	YL-4061
4" X 3"	16	4"	7-1/2"	12-3/32"	3"	6-13/32"	12"	YL-4071
4" X 3-1/2"	16	4"	8-3/4"	13-7/32"	3-1/2"	6-13/16"	14"	YL-4081
4"	16	4"	10"	14-11/32"	4"	7-1/4"	14"	YL-4091
5" X 2-1/8"	14	5"	5"	10-17/32"	2-1/8"	6-1/8"	13"	YL-5051
5" X 2-1/2"	14	5"	6"	11-13/32"	2-1/2"	6-7/16"	13"	YL-5061
5" X 3"	14	5"	7-1/2"	12-19/32"	3"	6-29/32"	15-1/2"	YL-5071
5" X 3-1/2"	14	5"	8-3/4"	13-23/32"	3-1/2"	7-5/16"	15-1/2"	YL-5081
5" X 4"	14	5"	10"	14-27/32"	4"	7-3/4"	15-1/2"	YL-5091
5"	14	5"	12-1/2"	17-9/16"	5"	9"	18-1/2"	YL-5151
6" X 2-1/8"	14	6"	5"	11-1/32"	2-1/8"	6-5/8"	15"	YL-6051
6" X 2-1/2"	14	6"	6"	11-29/32"	2-1/2"	6-15/16"	15"	YL-6061
6" X 3"	14	6"	7-1/2"	13-3/32"	3"	7-13/32"	15"	YL-6071
6" X 3-1/2"	14	6"	8-3/4"	14-7/32"	3-1/2"	7-13/16"	17"	YL-6081
6" X 4"	14	6"	10"	15-11/32"	4"	8-1/4"	17"	YL-6091
6" X 5"	14	6"	12-1/2"	18-1/16"	5"	9-1/2"	21"	YL-6141
6"	14	6"	15"	20-25/32"	6"	10-25/32"	21"	YL-6151
8" X 2-1/8"	14	8"	5"	12-1/32"	2-1/8"	7-5/8"	18"	YL-8051
8" X 2-1/2"	14	8"	6"	12-29/32"	2-1/2"	7-15/16"	18"	YL-8061
8" X 3"	14	8"	7-1/2"	14-3/32"	3"	8-13/32"	18"	YL-8071
8" X 3-1/2"	14	8"	8-3/4"	15-7/32"	3-1/2"	8-13/16"	21"	YL-8081
8" X 4"	14	8"	10"	16-11/32"	4"	9-1/4"	21"	YL-8091
8" X 5"	14	8"	12-1/2"	19-1/16"	5"	10-1/2"	24"	YL-8141
8" X 6"	14	8"	15"	21-25/32"	6"	11-25/32"	24"	YL-8151
8"	14	8"	20"	27"	8"	14-5/32"	29"	YL-8161
10" X 2-1/8"	12	10"	5"	13-1/32"	2-1/8"	8-5/8"	21"	YL-10051

- EXPANDED ENDS STANDARD THROUGH 6" SIZE
- * SEGMENTED

KEY

OD = Outside Diameter
D = Expansion Depth 1-3/8" through 4" OD, 1-5/8" for 5" and 6" OD
A = Outside Diameter (OD) = E Inside Diameter (ID)
F = Outside Diameter (OD) = G Inside Diameter (ID)
L = Expansion Depth 1-3/8" through 4" OD, 1-5/8" for 5" and 6" OD
All reference dimensions are nominal.

